

SASHA W/P OWNER'S MANUAL



Wilson Audio® is a registered trademark of Wilson Audio Specialties, Inc.

WATT/Puppy®, WAMM®, Cub®, Sophia®, Sasha W/P™, MAXX®, and Alexandria® are registered trademarks of Wilson Audio Specialties, Inc.

WilsonGloss™, Duette™, WATCH Center™, WATCH Surround™, and WATCH Dog™ are trademarks of Wilson Audio Specialties, Inc.

This manual was produced by the Wilson Audio Engineering and the Sales and Marketing Department. The information contained herein is subject to change without notice. Current Revision 1.8. If you are in need of a more recent manual, please contact your dealer.

The information in this manual is the sole property of Wilson Audio Specialties, Inc. Any reproduction, in whole or in part, without the express written permission of Wilson Audio Specialties, Inc., is prohibited. No material contained herein may be transmitted in any form or by any means, electronic or mechanical, for any purpose, without the express written permission of Wilson Audio Specialties, Inc.



SECTION 1 – IN YOUR ROOM 7

SECTION 1.1 – ROOM ACOUSTICS..... 9

 FINAL LISTENING ROOM SETUP (VOICING)..... 9

SECTION 1.2 – WILSON AUDIO SETUP PROCEDURE (WASP) 9

ZONE OF NEUTRALITY..... 9

SECTION 1.3 – ROOM REFLECTIONS 11

 SLAP ECHO..... 11

 STANDING WAVES 13

 COMB FILTER EFFECT..... 15

SECTION 1.4 – RESONANCES 15

 STRUCTURAL RESONANCE..... 16

 VOLUME RESONANCE..... 16

SECTION 1.5 – YOUR ROOM 17

 ROOM SHAPES 17

 SASHA W/P IN A DEDICATED HOME THEATER 18

 SPEAKER PLACEMENT VERSUS LISTENING POSITION 19

 SPEAKER ORIENTATION 19

 SUMMARY 20

SECTION 2 – UNCRATING SASHA W/P 23

SECTION 2.1 – UNCRATING THE SASHA W/P 25

 INITIAL CHECK 25

 UNCRATING THE WOOFER MODULE 25

 UNCRATING THE UPPER MIDRANGE/TWEETER MODULE..... 26

SECTION 2.2 – CRATE CONTENT CHECKLIST..... 26

SECTION 3 – ASSEMBLING SASHA W/P 29

SECTION 3.1 – INITIAL ASSEMBLY 31

PREPARATION	31
UPPER MIDRANGE/TWEETER MODULE ASSEMBLY	31
MOUNTING THE UPPER MIDRANGE/TWEETER MODULE.....	32
UMBILICAL CONNECTIONS.....	34
SECTION 4 – FINISHING UP	37
SECTION 4.1 – SPIKING THE SASHA W/P	39
WOOFER MODULE SPIKES	39
SPIKE/DIODE ASSEMBLY	39
INSTALLATION PROCEDURE.....	41
SECTION 4.2 – LEVELING THE SASHA W/P	41
SECTION 4.3 – REMOVING THE PROTECTIVE FILM	42
SECTION 4.4 – RESISTORS.....	43
WOOFER DAMPING RESISTOR.....	44
SECTION 5 – CARE OF SASHA W/P	45
SECTION 5.1 – CARE OF THE FINISH	47
DUSTING THE SASHA W/P.....	47
CARE OF THE GRILLES.....	48
BREAK-IN PERIOD.....	48
SECTION 5.2 – ENCLOSURE TECHNOLOGY	48
MATERIALS	48
ADHESIVE.....	49
SECTION 5.3 – DEPTH OF DESIGN	49
SECTION 6 – TROUBLESHOOTING	53
SECTION 6.1 – TROUBLESHOOTING.....	55
SECTION 7 – SYSTEM SPECIFICATIONS	59

SECTION 7.1 – SPECIFICATIONS	61
SECTION 7.2 – SASHA W/P DIMENSIONS	62
SECTION 8 – PROPAGATION DELAY TABLES	63
SECTION 8.1 – PROPAGATION DELAY TABLES	64
SECTION 9 – WARRANTY INFORMATION	67
SECTION 9.1 – WARRANTY INFORMATION	69
LIMITED WARRANTY	69
CONDITIONS	69
REMEDY.....	70
WARRANTY LIMITED TO ORIGINAL PURCHASER	70
DEMONSTRATION EQUIPMENT	71
MISCELLANEOUS.....	71

SECTION 1 - IN YOUR ROOM



Section 1.1 – Room Acoustics

You are surely excited about setting up Sasha W/P™ loudspeakers and doing some listening, but before you begin, we would like to discuss some of the important room acoustical information that will help you set up your loudspeakers properly.

Final Listening Room Setup (Voicing)

For a speaker system its size, the Sasha W/P is unmatched in its ability to reproduce the musical event. It is truly state of the art. However, room acoustics and boundary interactions affect the sound of a loudspeaker to such a large degree that poor setup can seriously degrade your enjoyment of even the finest loudspeaker.

Therefore, we offer the following section, which will present some guidelines on room acoustics and their interactions with loudspeakers. While we will also outline some detailed suggestions on the setup of the Sasha W/P, we strongly suggest that you have your local Wilson Audio dealer perform the final speaker “voicing” with you. Wilson dealers are specially trained in setting up Wilson loudspeakers and will ensure that you realize the full value of your purchase.

Section 1.2 – Wilson Audio Setup Procedure (WASP)

Zone of Neutrality

The “Zone of Neutrality” is an area in your room where the speakers will sound most natural. This location is where the speakers interact the least with adjacent room boundaries. It is important to have a clear working space while determining the Zone of Neutrality.

The following is a simple method to locate the Zone of Neutrality within your listening environment:

1. Stand against the wall BEHIND the location where you intend to position

Sasha W/P. Speaking in a moderately loud voice and at a constant volume, project your voice out into the room. Your voice will have an overly heavy, “chesty” quality because of your proximity to the rear wall.

2. While speaking, slowly move out into the room, progressing in a direction parallel to the sidewall. It is helpful to have another listener seated in the listening position to assist you during this process. Listen to how your voice “frees up” from the added bass energy imparted by the rear wall boundary. Also notice that your voice is quite spatially diffuse (to your assistant, your voice will sound spatially large and difficult to localize) as you begin to ease away from the rear wall.
3. At some point during your progression forward into the room, you will observe a sonic transition in your voice; it will sound more tonally correct and less spatially diffuse (your assistant can now precisely localize the exact origin of your voice). When you hear this transition, you have entered the inner edge of the Zone of Neutrality. Place a piece of tape on the floor to mark this location. Although it will vary from room to room, the zone in most rooms begins between two and a half to three feet from the rear wall.
4. Continue to walk slowly away from the rear wall. After some distance, usually one to two feet past the first piece of tape, you will begin to hear your voice lose focus and appear to reflect (echo) in front of you. This is caused by the return of the room’s boundary contribution; your voice is now interacting with the opposite wall. At the point where you begin to hear the reflected sound of your voice, you have reached the inner edge of the Zone of Neutrality. Place a piece of tape on the floor and mark this location. The distance between the “inner” and “outer” edge tape marks is usually between eight inches (for small, interactive rooms) and three feet (for large, more neutral rooms).
5. Now position yourself against the side wall perpendicular to the intended speaker location. Stand between the two tape marks. Using the same procedure as above, begin moving into the room toward the opposite sidewall, progressing between the two pieces of tape. As above, listen

for the point in the room where your voice transitions from bass-heavy and diffuse to neutral. Mark this point with tape. Continue your progression until there is an obvious interaction with the opposite wall in front of you and mark this point with tape. The four pieces of tape now form a rectangle that establishes the Zone of Neutrality for the loudspeaker located on that side of the room. Using the four marks as your guide, tape an outline to define the boundaries of the rectangle.

6. Repeat this process for each speaker location individually. These are your Zones of Neutrality, one for each channel.

Theoretically, the Zone of Neutrality for any room runs like a path, parallel to the walls all around the room. Adjacent to very large windows and open doors, the outer edge of the Zone of Neutrality moves closer to the wall and becomes wider. If you were to extend the inner and outer boundaries of the Zone for the sidewalls and the front wall (behind the speakers), they would intersect. After you complete this procedure for the other loudspeaker, you will now have two rectangles, one on the floor on either side of the room.

Section 1.3 – Room Reflections

Note: The following section contains general information on room acoustics and loudspeaker/room interaction. The concepts outlined below are equally relevant when dealing with multi-channel audio or home theater. The careful application of these concepts, as you evaluate the acoustical characteristics of your own room configuration, will allow you to optimize the performance of Sasha W/P.

Slap Echo

Probably the most obnoxious form of reflection is called “slap echo.” With slap-echo, primarily midrange and high frequency sounds reflect off of two parallel hard surfaces. The sound literally reverberates back and forth until it is finally dissipated over time. You can test for slap echo in any room by clapping your hands sharply in

the middle of the room and listening for the characteristic sound of the echo in the midrange. Slap echo destroys the sound quality of a stereo system in two ways:

- It adds harshness to the upper midrange and treble by storing time-domain smearing energy.
- It destroys the delicate phase relationships, which help to establish an accurate soundstage.

Slap echo (see Figure 1) is a common acoustical problem in the typical domestic listening room because most of these rooms have walls with a hard, reflective nature, only occasionally interrupted by curtains, wall art, or drapes. The best (but least practical) solution to eliminate slap echo is nonparallel walls. This is because, rather than support slap-echo, nonparallel walls allow the sound to diffuse. This approach can be

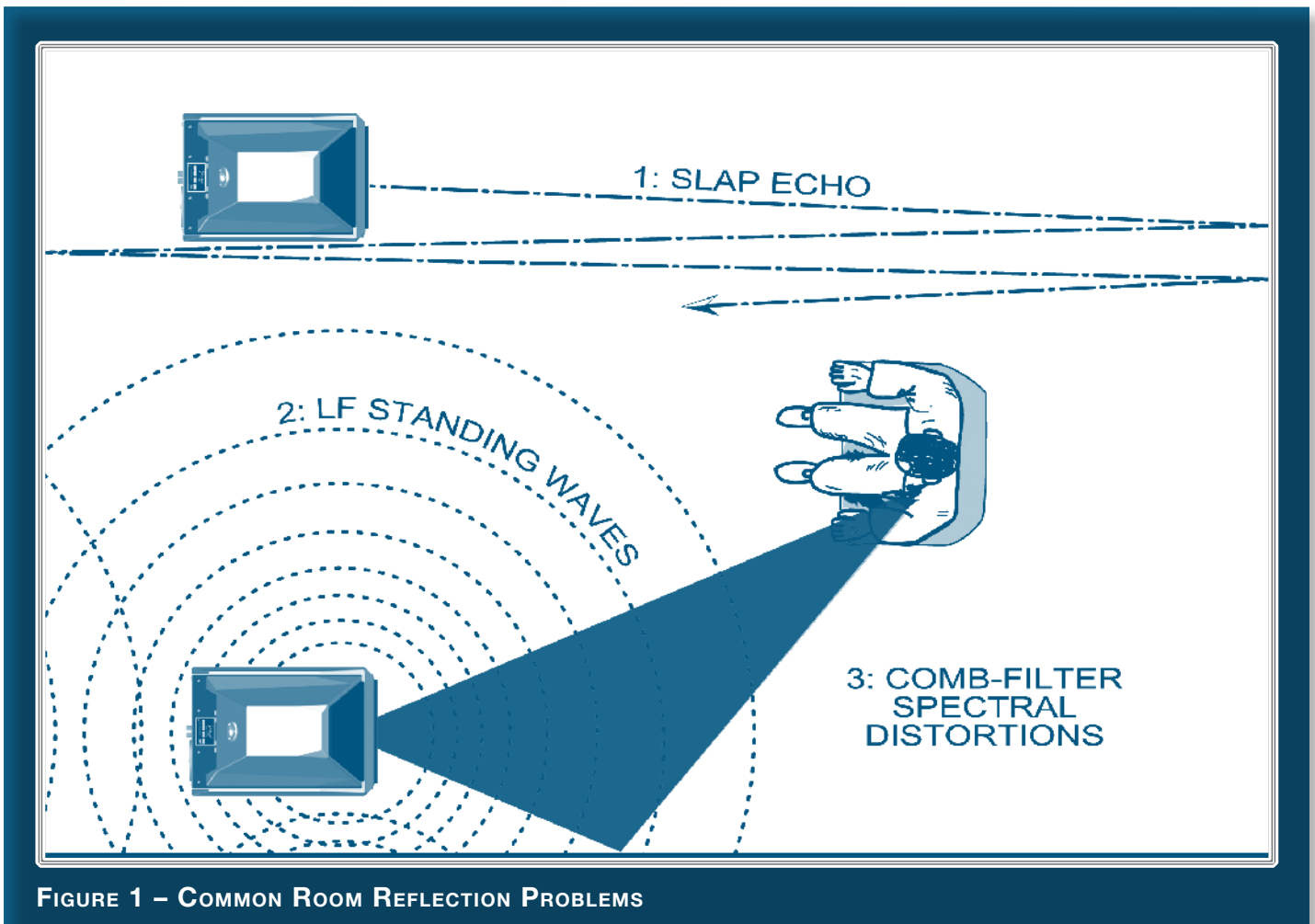

FIGURE 1 – COMMON ROOM REFLECTION PROBLEMS

accounted for during the construction process. For existing rooms, slap echo can also be controlled entirely by the application of absorptive materials to the hard surfaces.

These are absorptive materials that can be used to ameliorate slap echo:

- Pinta Acoustic Sonex®
- Air duct board
- Cork panels
- Large ceiling to floor drapes
- Carpeting to wall surfaces

In many domestic listening environments, heavy stuffed furnishings reduce slap echo somewhat. Unfortunately, their effectiveness is not predictable. Diffusers are sometimes also used to very good subjective effect, particularly in quite large rooms. Sound absorbent materials such as described above will alter the tonal characteristic of the room by making it sound “deader,” less “bright and alive,” and “quieter.” These changes usually make the room more pleasant for conversation, but sometimes render it too dull in the high frequencies to be musically involving. Soundtrack effects will be more localized. However, over-damping the room can render reproduced sound that is lacking in musical involvement and “aliveness.”

Diffusers, on the other hand, do not affect the tonal balance characteristic of the room as much. Placed properly, diffusers create a smoother and more open sound. Some diffusers, due to their construction, create narrow midrange peaks and suck-out the warmth region. Do not use diffusers on the wall behind the speakers or on the sidewalls directly beside the speakers. It is our experience that all of these room treatment devices should be used judiciously.

Standing Waves

Another type of reflection phenomenon is “standing waves.” Standing waves

cause the unnatural boosting or accentuation of certain frequencies, typically in the bass, to be found at certain discreet locations in the room. These locations differ according to room dimension and size. A room generating severe standing waves creates difficulty in setup. In these rooms, the speaker will sound radically different as it is moved around. The effects of standing waves on a loudspeaker's performance are primarily in the areas listed.

- Tonal balance
- Resolution of low-level detail
- Soundstaging

Standing waves are more difficult to correct than slap echo because they tend to occur at a lower frequency. Absorbent materials, such as Pinta Acoustic Sonex®, are ineffective at controlling reflections in the bass region. Moving speakers about slightly in the room is, for most people, their only control over standing waves. Sometimes a change of placement of as little as two or three inches can dramatically alter the tonal balance of a small system.

Fortunately, minor low frequency standing waves are well controlled by positioning ASC Tube Traps™ in the corners of the room. Very serious low frequency accentuation usually requires a custom-designed bass trap system.

Low frequency standing waves can be particularly troublesome in rooms constructed of concrete or brick. These materials trap the bass in the room unless it is allowed to leak out of the room through windows and doors.

In general, placement of the speaker in a corner will excite the maximal number of standing waves in a room and is to be avoided for most direct radiator, full-range loudspeaker systems. Some benefit is achieved by placing the stereo pair of loudspeakers slightly asymmetrically in the listening room. This is so the standing waves caused by the distance between one speaker and its adjacent walls and floors are not the same

as the standing wave frequencies excited by the dimensions in the other channel.

Comb Filter Effect

The “comb filter” effect is a special type of standing wave noticeable primarily at higher frequencies and shorter wavelengths.

Acoustical comb filtering occurs when sound from a single source, such as a loudspeaker, is directed toward a microphone or listener from a distance. The first sound to reach the microphone is the direct sound, followed by a delayed, reflected sound. At certain frequencies, cancellation occurs because the reflected sound lags in phase relative to the direct sound. This cancellation is most apparent where the two frequencies are 180 degrees out of phase. Further, there is augmentation at other frequencies where the direct and the reflected sounds arrive in phase. Because it is a function of wavelength, the comb filter effect will notch out portions of the audio spectrum at linearly spaced intervals. Subjectively, comb filter effect evidences itself as follows:

- Added roughness to the sound
- Reduction of harmonic richness
- Smearing of lateral soundstage image focus and placement

Comb filter effects are often caused by side wall reflections. They are best controlled by very careful speaker placement and by the judicious placement of Pinta Acoustic Sonex® or air duct panels applied to that part of the wall where the reflection occurs.

Section 1.4 – Resonances

Resonance in listening rooms is generally caused by two sources:

- Structures within the listening room.
- The volume of air itself within the listening room.

Structural Resonance

Structural resonances are familiar to most people as buzzes and rattles, but this type of resonance usually only occurs at extremely high volume levels and is usually masked by the music. In many wood frame rooms the most common type of structural resonance problem is “booming” of walls and floors. You can test for these very easily by tapping the wall with the palm of your hand or stomping on the floor. Most rooms exhibit mid-bass “boom” when struck. The loudspeaker playing in the room also excites these resonances. To give you an idea of what the perfect wall would sound like, imagine rapping your hand against the side of a mountain. Structural wall resonances generally occur in the low to mid-bass frequencies and add a false fullness to the tonal balance. They, too, are more prominent at louder levels, but their contribution to the sound of the speaker is more progressive. Rattling windows, picture frames, lamp shades, etc., can generally be silenced with small pieces of caulk or with blocks of felt. However, short of actually adding additional layers of sheet rock to flimsy walls, there is little that can be done to eliminate wall resonances.

Volume Resonance

The physical dimensions and volume of air in a room will also support standing wave modes and resonances at frequencies determined by the size of that room. Larger rooms will resonate at a lower frequency and have more complex (better) modal distributions than will smaller rooms. Volume resonances, wall panel resonances, and low frequency standing waves combine to form a low frequency coloration in the sound. At its worst, it is a grossly exaggerated fullness, which tends to obscure detail and distort the natural tonal balance of the speaker system.

Occasionally, however, there is just enough resonance to give a little added warmth to the sound – an addition some listeners prefer. Careful placement of loudspeakers in the room can dramatically reduce the speakers’ destructive interaction with

low frequency modes. ASC Tube Traps™ are effective in reducing some of this low frequency room coloration. Custom designed bass traps, such as perforated Helmholtz resonators, provide the greatest degree of low frequency control.

Section 1.5 – Your Room

Room Shapes

Standing waves are pressure waves propagated by the interaction of sound and opposing parallel walls. This interaction creates patterns of low and high acoustical pressure zones that accentuate and attenuate particular frequencies. Those frequencies are dependent on room size and dimension.

There are three basic shapes for most rooms: square, rectangular, and L-shaped (see Figure 2).

A perfectly square room is the most difficult room in which to set up speakers. By virtue of its shape, a square room is the perfect medium for building and sustaining standing waves. These rooms heavily influence the music played by loudspeakers, greatly diminishing the listening experience.

Long, narrow, rectangular rooms also pose their own special acoustical problems for speaker setup. They have the ability to create several standing wave nodes, which will have different standing wave frequency exaggerations depending on where you are sitting. Additionally, these long rooms are often quite lean in the bass near the center of the room. Rectangular rooms are still preferred to square rooms because, by having two sets of dissimilar length walls, standing waves are not as strongly reinforced and will dissipate more quickly than in a square room. In these rooms, the preferred speaker position for spatial placement and midrange resolution would be on the longer walls. Bass response would be reinforced by speaker placement on the short walls.

In many cases, L-shaped rooms (See Figure 2) offer the best environment for

speaker setup. Ideally, speakers should be set up along the primary (longest) leg of the room. They should fire from the end of the leg (short wall) toward the L, or they should be along the longest wall. In this way, both speakers are firing the same distance to the back wall. The asymmetry of the walls in L-shaped rooms resists the buildup of standing waves (see Figure 2).

Sasha W/P In A Dedicated Home Theater

Home theaters can be organized many different ways. Some use rows of couches. Others use rows of multiple chairs.

In addition to watching movies, most users want to listen to two-channel music at the highest quality possible. It is desirable, therefore, to choose a single optimum seating position in a home theater and build the rest of the seating positions around this position.

If your optimum position is

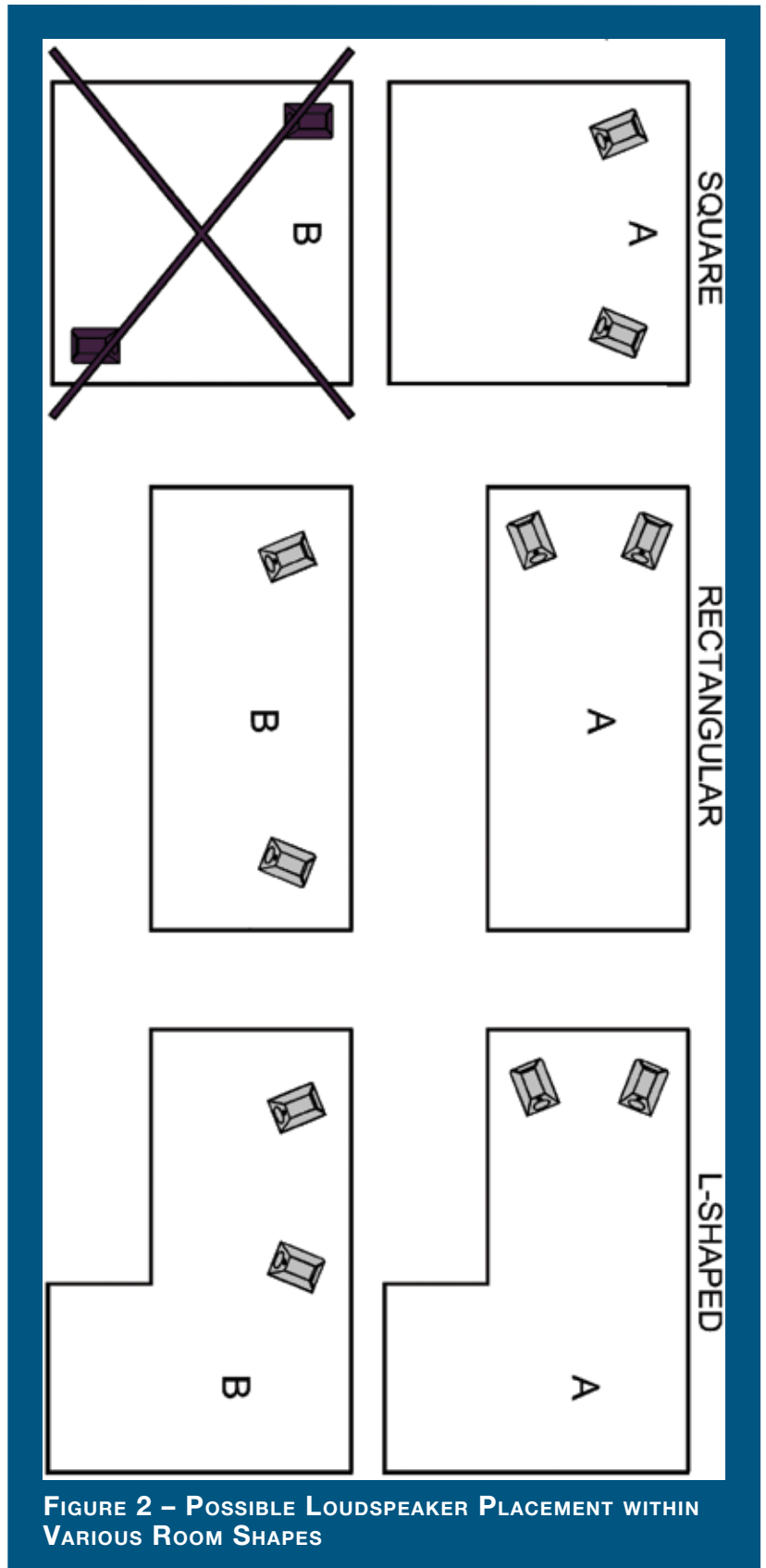

FIGURE 2 – POSSIBLE LOUDSPEAKER PLACEMENT WITHIN VARIOUS ROOM SHAPES

located on a couch, you should center the loudspeakers on the center position of the couch.

If the seating area consists of multiple rows of chairs, the second row should be optimized for the best sound quality. Odd numbers of chairs arranged in rows work best as this will allow a single chair to be positioned in the center. This approach will also provide the best overall sound for the greatest number of seats.

Speaker Placement Versus Listening Position

The location of your listening position is as important as the careful setup of Sasha W/P speakers. The listening position should ideally be no more than 1.1 to 1.25 times the distance between the tweeters on each speaker. Therefore, in a long, rectangular room of 12' x 18', if the speaker tweeters are going to be 9' apart, you should be sitting 9'11" to 11'3" from the speaker. This would be more than halfway down the long axis of the room.

Many people place the speakers on one end and sit at the other end of the room. This approach will not yield the finest sound. Carefully consider your listening position. Our experience has shown that any listening position that places your head closer than 14" from a room boundary will diminish the sonic results of your listening. Sitting directly in the center of the room will noticeably reduce the perception low frequencies.

Decide where you want your favorite listening position to be. Please remember that Sasha W/P will fill almost any room with the most beautiful sound available. Because the propagation delay is adjustable on the Sasha W/P, if you take care in placing your new speakers, you will optimize Sasha W/P's performance in your room.

Speaker Orientation

Speaker placement and orientation are two of the most important considerations in obtaining superior sound. The first thing you need to do is eliminate the sidewalls

as a sonic influence in your system. Speakers placed too close to the sidewalls will suffer from a strong primary reflection. This can cause out-of-phase cancellations, or comb filtering, which will cancel some frequencies and change the tonal balance of the music. The Wilson Audio Setup Procedure (Section 1.1) is the best method with which to position your loudspeakers. Start with the speakers about 18" from each wall and, if you need to move them relative to the side wall, move them away from the wall, not closer.

A very important aspect of speaker placement is how far from the back wall to place the speakers. The closer a loudspeaker is to the back wall, the more pronounced the low bass energy and centering of the image will be. However, this comes at a definite reduction in stage size and bloom as well as a deterioration of upper bass quality. You must find the proper balance of these two factors, but remember, if you are partial to bass response or air and bloom, do not overcompensate your adjustments to maximize these effects. Overcompensated systems are sometimes pleasing in the short-term, but long-term satisfaction is always achieved through proper balance.

The Sasha W/P is designed for maximum phase coherence and pulse replication accuracy when each speaker is aimed directly at the listener or microphone. Thus, Sasha W/P should be "toed in." In other words, the listener, when seated in the listening position looking forward with his/her head in a rested position, should just barely see the surface of the inner side of each Sasha W/P. Toeing in the speakers provides meaningful improvements in resolution of low-level detail in the midrange as well as appreciable improvements in soundstaging performance.

Summary

In summary, for optimal tonal balance accuracy, resolution of low level detail, and soundstaging performance, the Sasha W/P should be positioned as outlined in this section. Ideally, the speakers should not be positioned too far from the listener if

maximum resolution of low-level detail is required. If possible, the speakers should be positioned out into the room, slightly asymmetrically vis-a-vis the side and rear walls. The speakers should be “toed in” toward the listener, preferably so that the listener, at his seated position, can barely see the surface of the inner side of the Sasha W/P as he/she faces the speaker. It is recommended that a distance of two to three feet, and possibly more, be maintained between the Sasha W/P and the rear walls and that a distance of at least two feet be maintained between the front panel of the Sasha W/P and reflective side walls. Depending on the room, judicious use of sound absorbent materials will reduce the space requirement.

By following the guidelines in this manual, your new Sasha W/P loudspeakers can provide you with a lifetime of pure music reproduction.

SECTION 2 - UNCRATING SASHA W/P



Note: You will have two Upper Midrange/Tweeter Module enclosures as well as two Woofer Module enclosures to unpack. The two modules will need to be separated into right and left channels. Clear out two spaces, one for your left and one for your right channels. Place the ODD numbered modules in the LEFT channel section and the EVEN in the RIGHT channel position.

Section 2.1 – Uncrating the Sasha W/P

Initial Check

The Sasha W/P is shipped in three wooden crates. Upon receiving these crates, please check their condition. If any of the crates are damaged, please report it to the shipping company immediately for insurance verification.

The following items are recommended for this procedure:

- Electric Screwdriver
- Phillips head drive bit
- Masking tape (for use in speaker setup)

Uncrating the Woofer Module

A minimum of two strong adults is required to set up the Sasha W/P. Locate the two largest crates labeled “Woofer Module.” These contain the woofer enclosures and are the first components of the system to unpack.

1. With the crate lid facing up, unscrew the wood screws securing the lid. Remove the lid.
2. Carefully turn the crate upright so that the Woofer Module is now vertical. With the Woofer Module’s bottom toward the floor, reach in and gently slide the Woofer Module out of the crate, carefully, so as not to hit the Woofer Module on the crate and scratch the paint.
3. Place the Woofer Module with an odd serial number on the left side of the room and the Woofer Module with an even serial number on the right

side of the room.

Note: These two woofer enclosures are very heavy and care should be taken to prevent injury.

Uncrating the Upper Midrange/Tweeter Module

The Upper Midrange/Tweeter Modules are contained in a single crate. Unpack the modules using the following procedure:

1. With the crate lid facing up, unscrew the wood screws securing the lid. Remove the lid.
2. The Upper Module crate contains the owner's manual and tool kit. Remove these.
3. When removing the upper modules, take care so as not to hit the modules on the crate and scratch the paint. Using the small shelf on the rear of the module, tilt it so there is access to the bottom side. Slide the other hand under the Upper Midrange/Tweeter Module for support, and carefully lift the enclosure out of the crate.
4. The cloth grilles are attached to the modules. Detach the grilles from the module and remove the protective plastic covering the grill.
5. Place the Upper Midrange/Tweeter Module with an odd serial number on the left side of the room and the module with an even serial number on the right side of the room.

Section 2.2 – Crate Content Checklist

Now that you have unpacked your Sasha W/Ps, you can inventory all the additional items in the crates.

- 1 - Owner's Manual
- 1 - Warranty Registration

- 2 - Pin Style Grilles (1 per enclosure)
- 6 - "A" Spikes
- 2 - #2 Spikes
- 2 - #3 Spikes
- 2 - #4 Spikes
- 1 - 1/8" Allen Wrench
- 1 - 1/2" Nut Driver
- 1 - Polishing Cloth
- 2 - Pin Style Grilles (1 per enclosure)
- 8 - Spikes with Nut
- 8 - Woofer Module Spike assembly (with conical diode)
- 8 - Brass Spike Floor Protectors
- 16 - Round Diode Spacers
- 1 - 3/8"-16 x 2" Set Screw
- 1 - 3/8"-16 x 1 1/2" Set Screw
- 1 - 9/16" Combo Wrench
- 1 - 1 5/32" Allen Wrench
- 1 - Polishing Cloth

Note: After set up of the system, keep the shipping crates in case of future shipping needs.

SECTION 3 - ASSEMBLING SASHA W/P



Note: Before setting up the Sasha W/P, study carefully Section 1, “In Your Room.” It provides valuable information on determining the ideal room location for your speakers.

Section 3.1 – Initial Assembly

Preparation

You will need the following items:

- Supplied hardware kit
- Tape measure
- Propagation Delay Correction Tables (Section 8)
- Known listening position
- Masking Tape

Take a moment to familiarize yourself with the top of the Woofer Module. It contains information that will be needed during the set-up. A complete set of Propagation Delay Correction Tables is located in Section 8.

Upper Midrange/Tweeter Module Assembly

The Upper Midrange/Tweeter Module uses the combination of three spikes installed into the bottom of its enclosure. The spikes

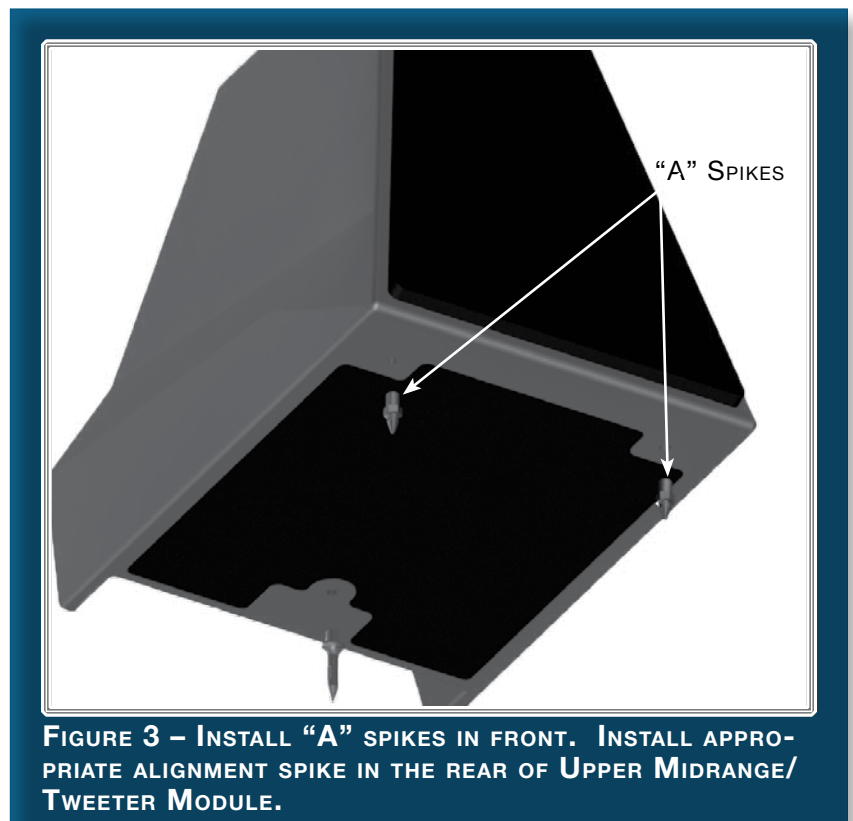

FIGURE 3 – INSTALL “A” SPIKES IN FRONT. INSTALL APPROPRIATE ALIGNMENT SPIKE IN THE REAR OF UPPER MIDRANGE/TWEETER MODULE.

provide proper coupling of the Upper Midrange/Tweeter Module to the Woofer Module and are used to correct propagation delay. "A" spikes are always installed in the front two positions (the threaded holes located near the bottom front of the enclosure). The spike-type is stamped in the round top of the spike. These two spikes screw into the Upper Midrange/Tweeter Module as shown in Figure 3. The spikes should be screwed in all the way, until they are hand tight. Do not over tighten spikes.

Mounting the Upper Midrange/Tweeter Module

- Place the Woofer Module enclosures into the selected room location (as determined by Section 1).
- Measure the listening distance and ear height (see example on Woofer Module top).
- Using the Propagation Delay Correction Table, select the required Alignment Spike.
- Install the rear-Alignment Spike until snug in the single rear hole.
- Carefully, place the Upper Mid-range/Tweeter Module's two front spikes into the rear of the Woofer Module guide track (see Figure 4). Hold

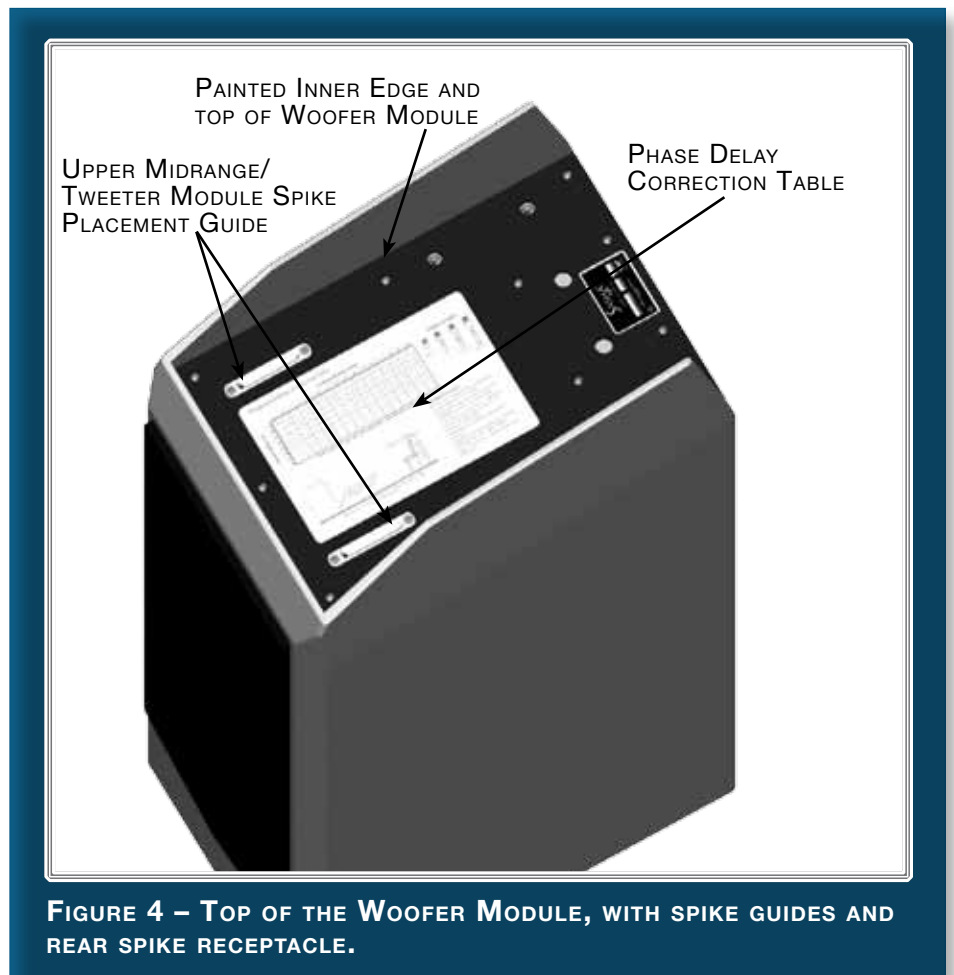

FIGURE 4 – TOP OF THE WOOFER MODULE, WITH SPIKE GUIDES AND REAR SPIKE RECEPTACLE.



FIGURE 5 – SLIDE THE UPPER MIDRANGE/TWEETER MODULE'S FRONT SPIKES ALONG THE GUIDES IN THE TOP OF THE WOOFER MODULE, KEEPING THE REAR OF THE UPPER MIDRANGE/TWEETER MODULE ELEVATED TO AVOID SCRATCHING THE WOOFER MODULE.

the back of the Upper Midrange/Tweeter Module above the Woofer Module surface such that the rear spike does not damage the top of the Woofer Module. Carefully slide the Upper Midrange/Tweeter Module forward, keeping the module elevated in the rear, until the front spikes rest securely in the front receptacle. Be careful not to damage the painted edges of the upper or lower modules.

- Use the small shelf on the Upper Midrange/Tweeter Module and slide the

module forward until the spikes slide into the spike receptacle (see Figure 5 above). The two front spikes will now be resting in the holes of the receptacle atop the Woofer Module.

Note: Ensure that the two front spikes are properly in their receptacles and that the Upper Midrange/Tweeter Module is not skewed atop the Woofer Module. The Upper Midrange/Tweeter Module sides should be parallel to the sides of the Woofer Module. This will ensure correct propagation alignment of the drivers.

Umbilical Connections

The correct connection of the two umbilicals to the Upper Midrange/Tweeter Module is as follows:

- There are two sets of connections on the Upper Midrange/Tweeter Module, one for the mid-range and the other for the tweeter.
- Locate the cable marked "MID FREQ." This cable



exits the Woofer Module just below the appropriate connector. Connect the RED lug of the cable to the RED (positive) terminal on the terminal labeled “Midrange” on the Upper Midrange/Tweeter Module. Connect the black lug of the cable to the BLACK (negative) terminal.

- Locate the cable marked “TWEETER.” Connect the RED lug at the load end of the tail to the RED terminal on the terminal labeled “Tweeter” on the Upper Midrange/Tweeter Module. Connect the black lug of the cable to the BLACK (negative) terminal.

Note: Please ensure that you do not invert the polarity of the umbilicals in the Sasha W/P. Such an inversion will produce entertaining ambient effects, but destroys the linearity and harmonic structure of the system.

SECTION 4 - FINISHING UP



Section 4.1 – Spiking the Sasha W/P

Your dealer is trained in the art and science of the Wilson Audio Setup Procedure (WASP) outlined in Section 1.1. Before the spike/diode assemblies are attached to the bottom of Sasha W/P, the set up and fine tuning of your loudspeaker should be completed. Before spiking Sasha W/P, use masking tape to carefully mark their location.

Woofers Module Spikes

Included with Sasha W/P are two sets of Woofer Module spikes, which provide acoustical isolation as well as optimal height placement for your speakers. There are three ways of assembling the spikes (without spacers, or with one or two spacers). Your choice will depend on your listening room and personal tastes. Wilson generally recommends no spacers, for simplicity and rigidity. However, the addition of spacers changes the driver-to-floor dimension and can sometimes be used to reduce an objectionable upper-bass/lower mid-range coloration in the sound.

Spike/Diode Assembly

1. Locate the spike assembly. On the spike, move the nut to about two threads from the point. This will allow for greater movement when leveling the loudspeaker system.
2. Screw the spikes into the diode until the nut is against the diode. Be careful that the nut does not turn while inserting and threading spikes into the diode.

Note: Do not tighten these assembled spikes. You will need to unscrew them when you level the Sasha W/P. This will ensure that if for any reason you have to remove Sasha W/P spikes, you will be able to withdraw the set screw using the supplied Allen wrench.

3. Screw the set screw into the diode until it meets the spike (see Figure 7).
4. Locate either the 1.5 inch or 2 inch (See Figure 7) set screw. The 1.5

inch is used with spikes and no spacers and with one spacer; the 2 inch is used with spikes and two spacers. Place the set screw into the other end of the diode with the Allen head toward the spike. Make sure the Allen key end is toward the spike end of the diode (See Figure 7). This will enable you to remove the bolt if necessary.

5. If desired, place the corresponding number of spacer discs over the bolt.
6. Assemble the rest of the spikes/diodes

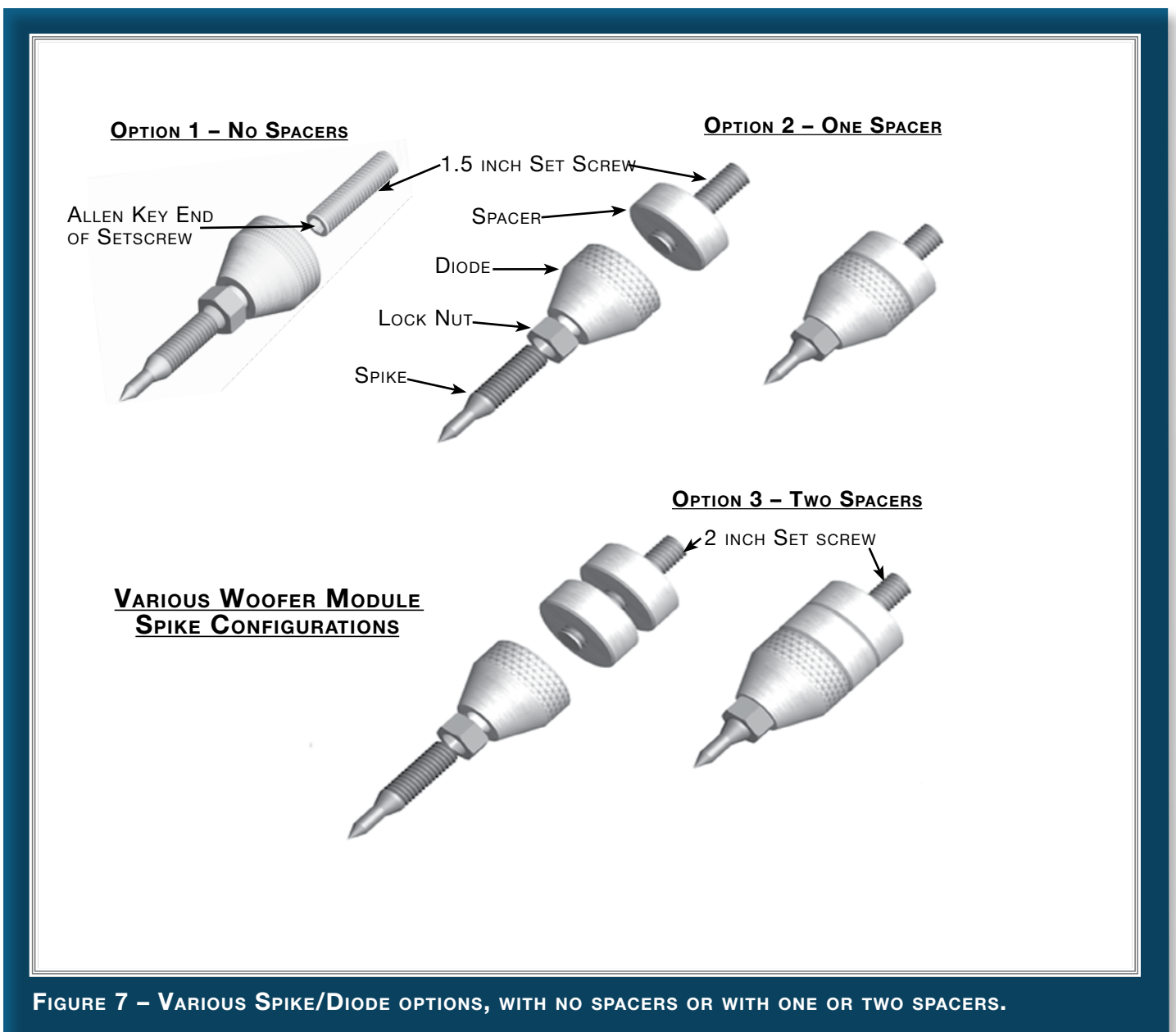

FIGURE 7 – VARIOUS SPIKE/DIODE OPTIONS, WITH NO SPACERS OR WITH ONE OR TWO SPACERS.

Installation Procedure

- Remove the Upper Midrange/Tweeter Module from the Woofer Module.
- Carefully lay the Woofer Module on its side.
- Insert the diode/spike assemblies into the four holes located on the bottom of each Woofer Module. Tighten until the top surface of the Woofer Module Spike (or spacer) touches the bottom surface of the “X” material plate.

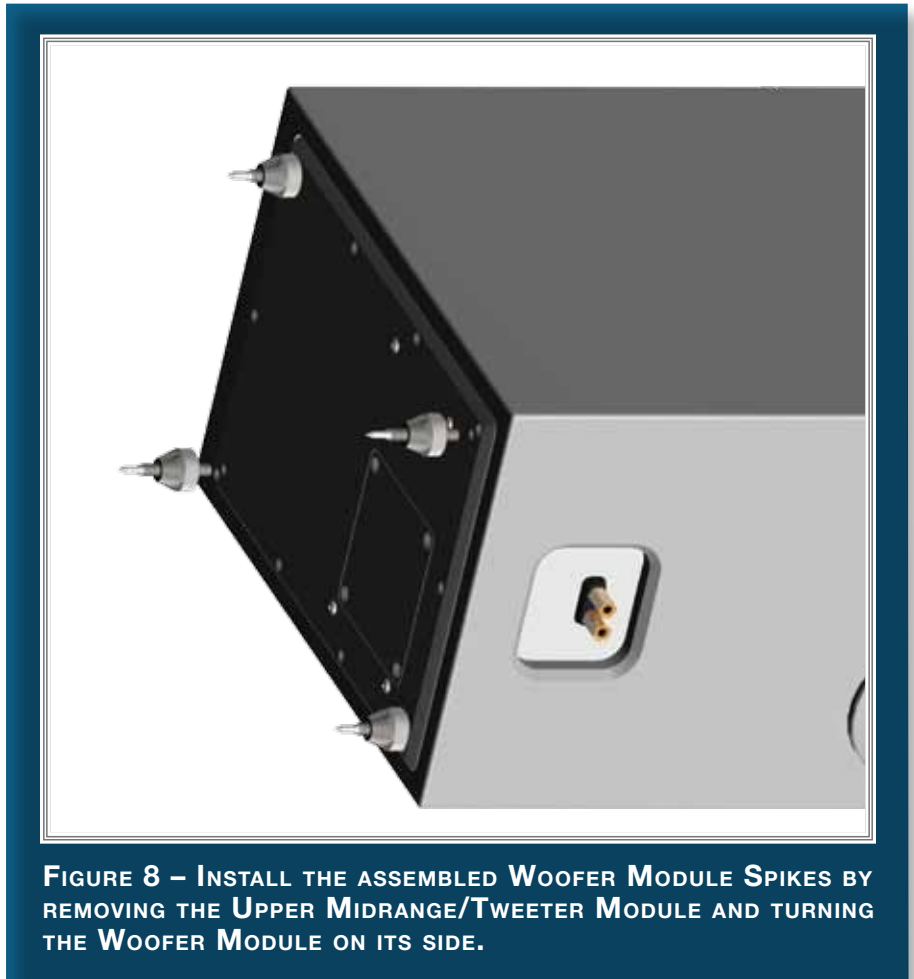

FIGURE 8 – INSTALL THE ASSEMBLED WOOFER MODULE SPIKES BY REMOVING THE UPPER MIDRANGE/TWEETER MODULE AND TURNING THE WOOFER MODULE ON ITS SIDE.

Note: The spike receptacles are tapped directly into the “X” material plate on the bottom of the Woofer Module. Be very careful NOT TO CROSS THREAD the spikes (see Figure 8).

Section 4.2 – Leveling the Sasha W/P

- Place a level on the left to right oriented axis in the flat area atop the woofer behind the Upper Midrange/Tweeter Module. If it is level, move to the next step.
- You may rotate the spike tips in place by using a vice-grip or toothed pliers.

- Lengthen the appropriate spike or spikes (not the Woofer Module Spike diode on the set screw) on that lower side until the Sasha W/P is level.
- If the speaker is leaning to the left, lengthen both Woofer Module spikes on the right hand side of the speaker. If the speaker is leaning right, lengthen the left hand spikes. Lengthen the spikes incrementally, checking and re-checking the level until the Sasha W/P is level left to right.
- Place a level on the front to back oriented axis. If it is level, then Sasha W/P is level. If the Sasha W/P is leaning one way or the other, following the same process as above, lengthen the appropriate spikes on the front or rear of the Woofer Module until the Sasha W/P is level.
- To find out which spike to lower, grasp the Sasha W/P channel and gently rock it back and forth. This will identify the spike that is out of level from the other three. If there is movement, lengthen the appropriate spike until the Sasha W/P sits solidly on the floor. Make sure the spike is penetrating the carpet surface and is resting on the solid floor beneath.
- Once all adjustments have been made, with the 9/16" wrench provided, tighten the nut on the spike to the diode. **DO NOT OVERTIGHTEN!** "Snug" is tight enough.

Section 4.3 – Removing the Protective Film

To protect the finish of the Sasha W/P during final manufacture, shipment, and setup in your listening room, we have applied a removable layer of protective film over the finish. We recommend that this film be left in place until the speakers are in their final location in your listening room. Once you have determined their final position, remove the film by following this procedure:

1. Ensure the speaker surface is room temperature before removing the protective film. Removing the protective film when the speaker surface is cold can damage the paint surface.
2. Slowly remove the film from the top down, large sections at a time, gently pulling the film downward and outward. Tearing the film aggressively

- can damage the paint.
3. Take care in removing the protective film near edges and corners to prevent paint damage in these areas.
 4. The protective film should not be left on the painted surface for extended periods of time nor exposed to heat sources and direct sunlight.

Section 4.4 – Resistors

By removing the large aluminum back cover on the rear of the woofer module of your Sasha W/Ps, you may gain access to the resistor plate (see Figure 10). These resistors serve several functions.

Note: Only Wilson Audio replacement resistors should be used in your Sasha W/Ps. Changing the value or brand of resistor will have a deleterious affect on the sonic performance of your loudspeakers and will void your Wilson Audio Warranty.

Midrange and Tweeter Resistors

The Midrange Level, which consists of two 3.2 ohm resistors in parallel, and Tweeter Level, which consists of two 1.6 ohm resistors in parallel, resistors provide precise level matching for the midrange and tweeter drivers correspondingly. The resistors also act as ultra high quality fuses which open before a driver can be damaged by excess power. See Section 6.0 for details in replacing these resistors in the event one of these resistors is damaged.

Additionally, these resistors can be used to tailor the output of the corresponding driver to overcome tonal balance issues that result from room acoustics.



FIGURE 9 – THE RESISTORS ARE LOCATED UNDER THE PLATE ON THE REAR OF THE WOOFER ENCLOSURE.

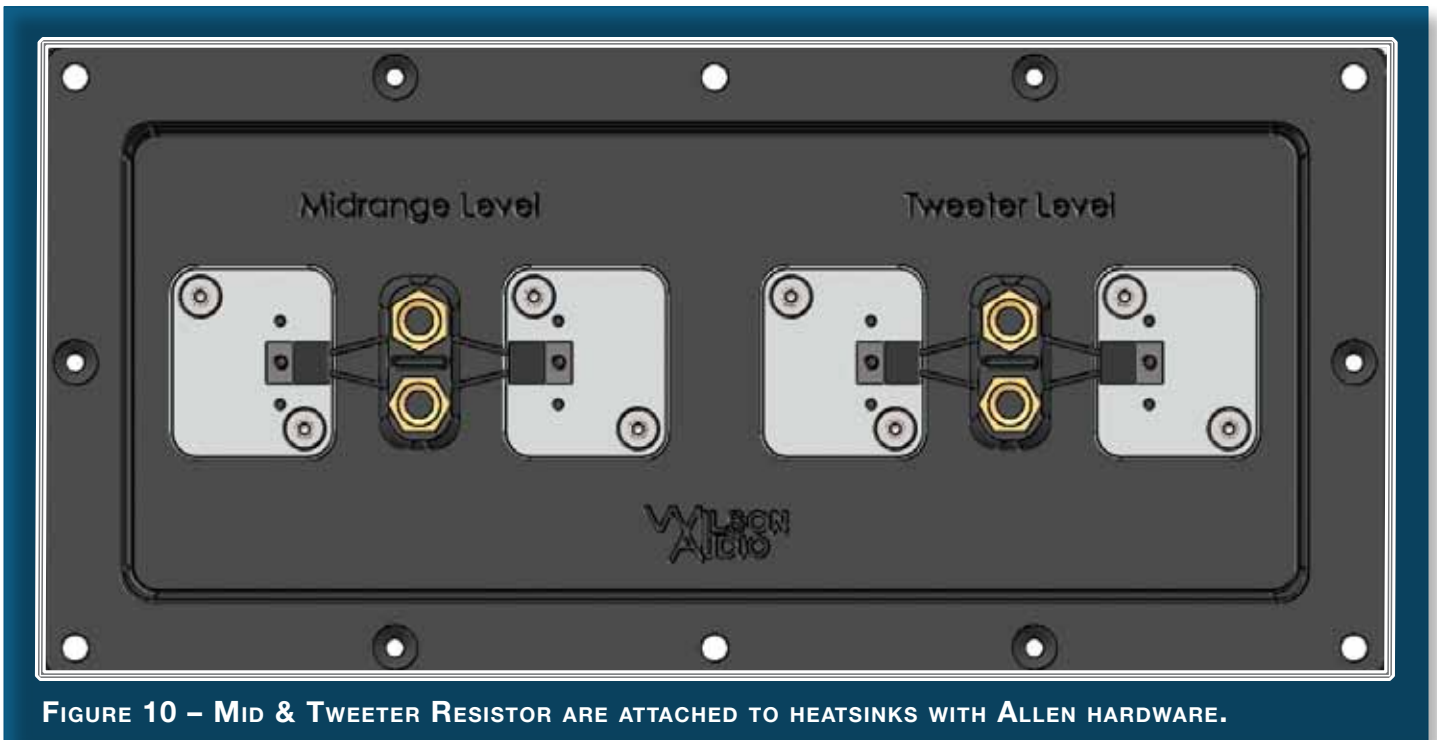

FIGURE 10 – MID & TWEETER RESISTOR ARE ATTACHED TO HEATSINKS WITH ALLEN HARDWARE.

Woofer Damping Resistor

The Woofer Damping resistor affects the way the Sasha W/P's woofers couple to the amplifier. These resistors are pre-installed in the base of the Bass Module and should not be changed.

SECTION 5 - CARE OF SASHA W/P



Section 5.1 – Care of the Finish

The Sasha W/P loudspeakers are hand painted with WilsonGloss™ paint and hand polished to a high luster. While the finish seems quite dry to the touch, final curing and complete hardening takes place over a period of several weeks.

Dusting the Sasha W/P

It is important that the delicate paint finish of the Sasha W/P be dusted carefully with the provided dust cloth. We recommend that the following procedure be observed when dusting the speakers:

- Blow off all loose dust.
- Using the special dust cloth as a brush, gently whisk off any remaining loose dust.
- Shake out the dust cloth.
- Dust the finish, using linear motions in one direction parallel to the floor. Avoid using circular or vertical motions.

Because the paint requires a period of several weeks to fully cure, we recommend that no cleaning fluids, such as glass cleaners, be used during this initial period of time. When the paint is fully cured, heavy fingerprints and other minor smudges may be removed with a glass cleaner. Always use the dust cloth. Stronger solvents are not recommended under any circumstances. Consult your dealer for further information if



required. To maintain the high luster of the finish, periodic polishing may be desired. We recommend a nonabrasive carnauba-based wax and a soft cloth.

Care of the Grilles

Periodically, you will want to clean the Sasha W/P's grilles. This is best done by using the round brush attachment on a vacuum cleaner hose. Gently vacuum the front surface of the grille. Be careful not to apply too much pressure. Do not use a hard plastic attachment against the grille. The grille cloth is stretched tightly over the grille frame. Too much pressure or use of a hard plastic attachment could cause the grille material to tear, especially in the corners.

Often Wilson speaker owners desire to change the look of their listening room by changing the color of their speaker grilles. In addition to basic black, Wilson Audio offers a variety of grille colors to match most WilsonGloss finishes. Contact your local dealer for grille cloth samples or to order replacement grilles for Sasha W/P.

Break-in Period

All audio equipment will sound best after its components have been broken in for some period of use. Wilson Audio breaks in all woofers and mid-range drivers for approximately 12 hours. All drivers are then tested, calibrated, and matched for their acoustical properties. In your listening room, expect 25 to 50 percent of break-in to be complete after two hours of playing music at normal listening levels. Ninety percent of break-in is complete after 24 hours of playing. Playing a CD on repeat overnight can accomplish this task quickly. Wilson Audio recommends chamber music for this task.

Section 5.2 – Enclosure Technology

Materials

Wilson Audio has conducted many hours of research on the impact of materials on

speaker enclosure performance. Through this effort, Wilson pioneered the use of non-resonant materials, first with the use of mineral-filled acrylic in the Upper Midrange/Tweeter Module and continuing with the further development of proprietary materials for X-1 Grand SLAMM and the original WATT/Puppy. Even the best materials are not suited to all aspects of enclosure construction. Therefore, like all Wilson loudspeakers, the Sasha W/P is constructed of several exotic materials chosen for their specific performance attributes relevant to different portions of the enclosure.

Sasha W/P is constructed using ultra-low-resonant, high-density, composites which are then cross-braced to further reduce cabinet resonance. Each of these composites meets and exceeds the highest of ANSI test standards for its use, while offering very tight tolerances, high hardness, uniform density, and dimensional stability.

Adhesive

Wilson Audio has conducted exhaustive research into the best adhesives to permanently bond our speaker enclosures. This is often an overlooked element crucial to the proper performance of a loudspeaker. Correct modulus of elasticity, coefficient of thermal expansion, and natural frequency response are just a few of the important elements of adhesives.

A highly cross-linked, thermo-set adhesive is used for the construction of the enclosure. It was also chosen for its excellent bond strength, solvent resistance, hardness, and optimum vibrational characteristics.

Section 5.3 – Depth of Design

Sasha W/P's compellingly authentic performance and lasting value are achieved through careful implementation of cutting edge design and engineering and then executed using the highest performance materials. Wilson Audio's use of proprietary

enclosure materials and adhesives are employed to achieve truly exceptional speaker cabinet performance. The use of these materials in Sasha W/P results in an enclosure that is inherently inert and non-resonant. All of these structural aspects are combined, allowing Wilson Audio to deliver a product that maintains the strictest structural tolerances, durability, and reliability. This also means that the Sasha W/P will have consistent, repeatable performance, unaffected by the climatic conditions, anywhere in the world. Finally, like all Wilson products, Sasha W/P is hand-crafted with meticulous attention to detail, with an unwavering commitment to excellence. Thus, Sasha W/P will impart to her owner beauty and pleasure for many years to come.



SECTION 6 - TROUBLESHOOTING



Section 6.1 – Troubleshooting

One channel is not operating:

Check the interconnects from source.

Check the connections on the speaker cables, both at the amplifier and speaker ends. Watch especially for connectors touching each other.

Check the umbilicals that connect the two modules. You may have forgotten to connect them, or they may have shorted or come loose during setup.

Imaging is off-center:

Check your connections. A connection to one of the modules may have come loose. When a tweeter or mid-range driver is not working, or is out of phase, the Sasha W/P will not “image” properly. Double check your connections for red-to-red and black-to-black.

Play music at a low level and listen to each driver in each channel. You may have a driver that is not operating correctly. If you find a driver that is silent, please go to the “Driver Out” section of this troubleshooting guide.

A chronic lack of bass energy:

Check the input cable connections on your woofer enclosure. If one channel is out of phase (connections reversed), bass will be cancelled. Note: Turn off your amplifier and unplug it from the wall.

Driver out or not playing after connections have been verified:

If you have found a driver with no output, move to the rear of this particular loudspeaker.

Using the appropriate Allen key, open the X-material door on the bottom of the Upper Midrange/Tweeter Module module.

You will find some resistor connections. Replace the resistor with the supplied matching resistor. Tighten the new resistor in the old one's place. The woofer resistor may be replaced in the same manner and is located behind the access door in the bottom of the Woofer Module.

Note: Use only Wilson Audio replacement resistors in Sasha W/P. These resistors were carefully chosen for the overall sonic and thermal performance.

Plug your amplifier into the wall and turn it on.

Listen to the channel at a low level. The driver should now be operating correctly.

Amplifier shuts off as soon as it is turned on:

Check to see if your speaker cables are properly secured. Look for frayed ends, loose connections, or a conductor contacting the amplifier chassis.

Turn the amplifier off and disconnect it from the AC wall outlet. Disconnect the preamplifier leads to the amplifier. Now turn on the amplifier.

If the problem is solved:

There is likely something wrong with your preamplifier or interconnect. Contact your dealer.

If the problem persists:

Leave the preamp leads disconnected

and continue to the next step.

Turn the amplifier off. Disconnect the speaker leads at the main input to the speaker. Now turn on the amplifier.

If the problem is solved:

Call your Wilson Audio dealer. There may be a problem with the crossover or the speaker's internal wiring.

If the problem persists:

Continue to the next step.

Turn the amplifier off and disconnect it from the AC wall outlet. Disconnect the speaker cable leads to the amplifier and turn the amplifier on again.

If the problem is solved:

You have a short in your speaker cables. Check for frayed ends, holes (from spike feet), or make sure that your spade lug is not touching the chassis while it is connected to the binding post.

If the problem persists:

Call the dealer where you bought your amplifier. You appear to have a problem with this component.

SECTION 7 - SYSTEM SPECIFICATIONS

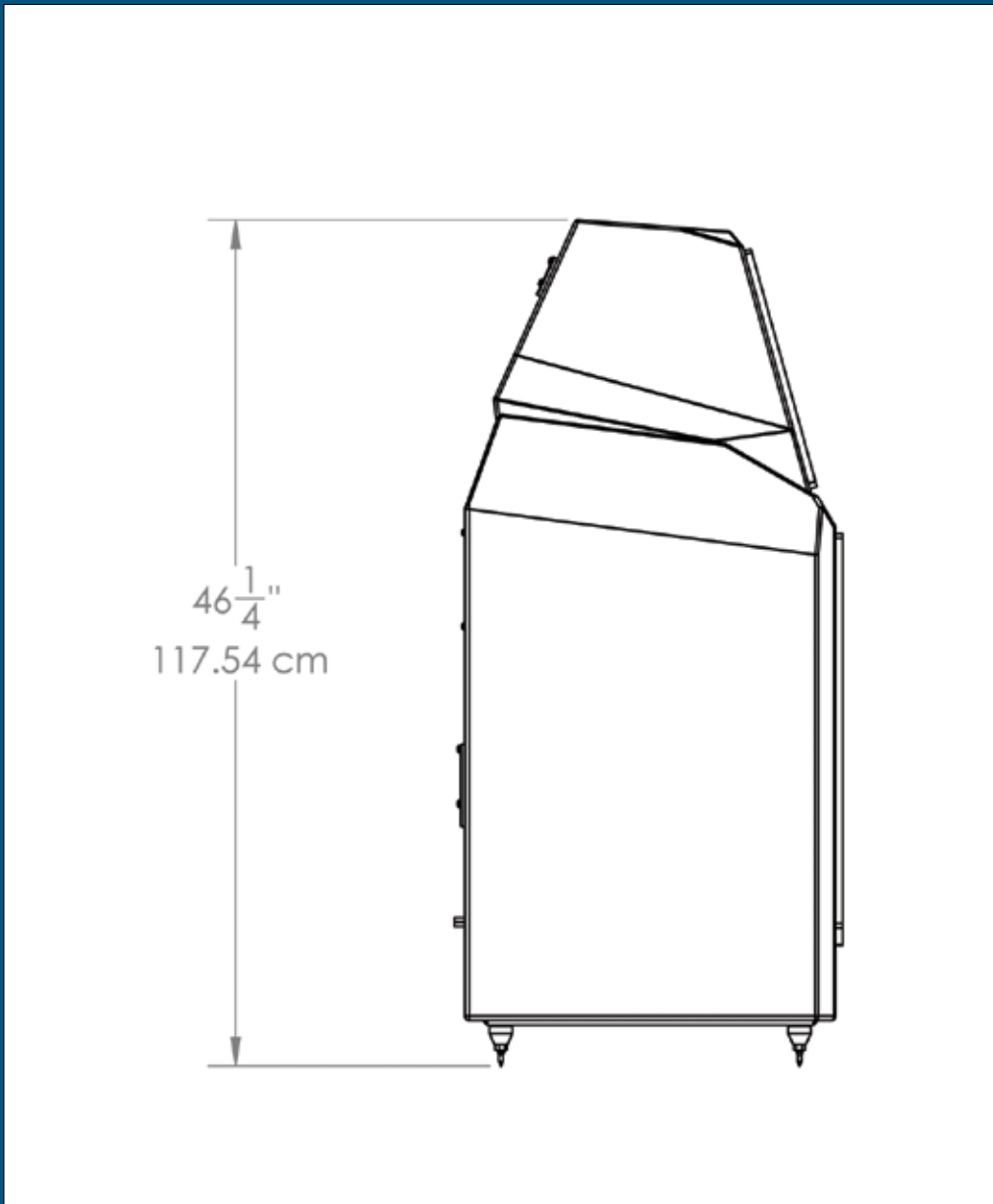

Section 7.1 – Specifications

Enclosure Type Upper Module: Rear Ported Midrange

Enclosure Type Woofer Module: Rear Ported Woofer

Woofers: Two – 8 inch (20.32 cm)

Midrange One – 7 inch (17.78 cm)

Tweeter: One – 1 inch inverted dome (2.54 cm)

Sensitivity: 91 dB (one watt at one meter)

Nominal Impedance: 4 ohms, 1.8 ohms minimum @ 92 Hz

Minimum Amplifier Power: 20 watts per channel

Frequency Response: +/- 3 dB 20 Hz - 22 kHz
(with port contribution)

Overall Dimensions: Height – 44 inches (111.76 cm)

Width – 14 inches (35.56 cm)

Depth – 21.25 inches (53.91 cm)

Sasha W/P Weight Per Channel: 197 lbs (89.36 kg)

System Shipping Weight (approx.): 605 lbs (274.42 kg)

Section 7.2 – Sasha W/P Dimensions

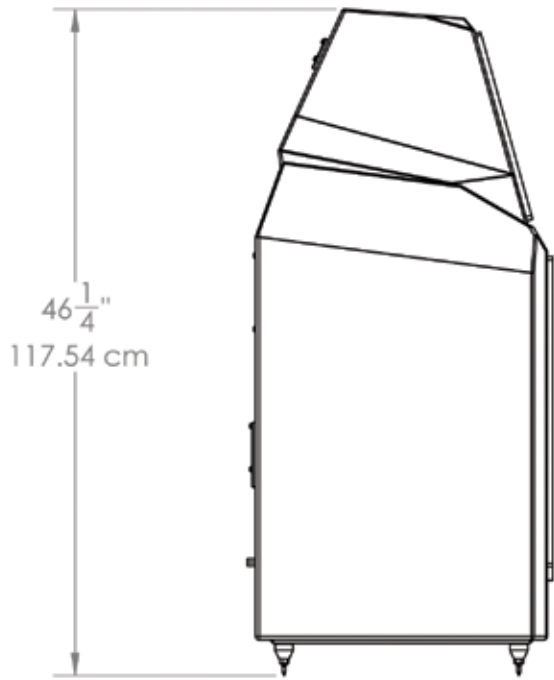
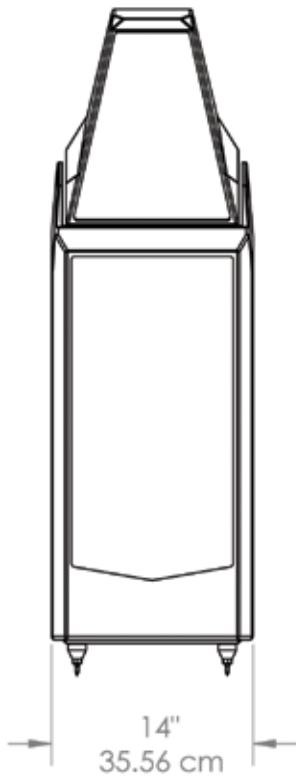
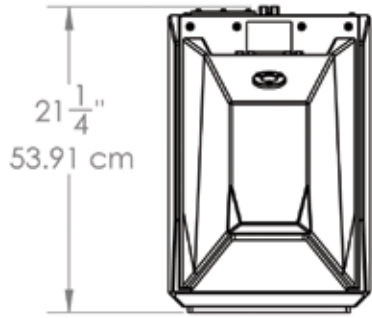

FIGURE 9

SECTION 8 - PROPAGATION DELAY TABLES



Section 8.1 – Propagation Delay Tables

Table Calculated for use with spike diode and no spacers

Ear Height (inches)	Listening Distance (feet)															
	5	6	7	8	9	10	11	12	13	14	15	16	17	18	19	20
34	4	4	4	4	4	4	4	4	4	4	4	4	4	4	4	4
36	3	4	4	4	4	4	4	4	4	4	4	4	4	4	4	4
38	2	3	3	4	4	4	4	4	4	4	4	4	4	4	4	4
40	2	2	3	3	3	3	3	4	4	4	4	4	4	4	4	4
42	A	A	2	2	3	3	3	3	3	3	4	4	4	4	4	4
44	A	A	A	2	2	2	2	3	3	3	3	3	3	4	4	4
46	A	A	A	A	2	2	2	2	3	3	3	3	3	3	4	4
48	A	A	A	A	A	2	2	2	2	2	3	3	3	3	3	3

Table Calculated for use with spike diode and one (1) spacer

Ear Height (inches)	Listening Distance (feet)															
	5	6	7	8	9	10	11	12	13	14	15	16	17	18	19	20
34	4	4	4	4	4	4	4	4	4	4	4	4	4	4	4	4
36	4	4	4	4	4	4	4	4	4	4	4	4	4	4	4	4
38	3	3	3	4	4	4	4	4	4	4	4	4	4	4	4	4
40	2	3	3	3	3	3	4	4	4	4	4	4	4	4	4	4
42	A	2	2	3	3	3	3	3	3	3	4	4	4	4	4	4
44	A	A	A	2	2	2	2	3	3	3	3	3	3	4	4	4
46	A	A	A	2	2	2	2	2	2	3	3	3	3	3	4	4
48	A	A	A	A	A	2	2	2	2	2	3	3	3	3	3	3

Table Calculated for use with spike diode and two (2) spacers

	Listening Distance (feet)															
	5	6	7	8	9	10	11	12	13	14	15	16	17	18	19	20
34	4	4	4	4	4	4	4	4	4	4	4	4	4	4	4	4
36	4	4	4	4	4	4	4	4	4	4	4	4	4	4	4	4
38	3	3	3	4	4	4	4	4	4	4	4	4	4	4	4	4
40	2	3	3	3	3	4	4	4	4	4	4	4	4	4	4	4
42	A	2	2	3	3	3	3	3	3	4	4	4	4	4	4	4
44	A	A	2	2	2	3	3	3	3	3	3	4	4	4	4	4
46	A	A	A	2	2	2	2	3	3	3	3	3	3	4	4	4
48	A	A	A	A	A	2	2	2	3	3	3	3	3	3	3	3

Ear Height (inches)

SECTION 9 - WARRANTY INFORMATION



Section 9.1 – Warranty Information

Limited Warranty

Subject to the conditions set forth herein, Wilson Audio warrants its loudspeakers to be free of manufacturing defects in material and workmanship for the Warranty Period. The Warranty Period is a period of 90 days from the date of purchase by the original purchaser, or if both of the following two requirements are met, the Warranty Period is a period of five (5) years from the date of purchase by the original purchaser:

Requirement No. 1. No later than 30 days after product delivery to the customer, the customer must have returned the Warranty Registration Form to Wilson Audio;

Requirement No. 2. The product must have been professionally installed by the Wilson Audio dealer that sold the product to the customer.

FAILURE TO COMPLY WITH EITHER REQUIREMENT NO. 1 OR REQUIREMENT NO. 2 WILL RESULT IN THE WARRANTY PERIOD BEING LIMITED TO A PERIOD OF 90 DAYS ONLY.

Conditions

This Limited Warranty is also subject to the following conditions and limitations. The Limited Warranty is void and inapplicable if the product has been used or handled other than in accordance with the instructions in the owner's manual, or has been abused or misused, damaged by accident or neglect or in being transported, or if the product has been tampered with or service or repair of the product has been attempted or performed by anyone other than Wilson Audio, an authorized Wilson Audio Dealer Technician or a service or repair center authorized by Wilson Audio to service or repair the product. Contact Wilson Audio at (801) 377-2233 for information on location of Wilson Audio Dealers and authorized service and repair centers. Most repairs can

be made in the field. In instances where return to Wilson Audio's factory is required, the dealer or customer must first obtain a return authorization. Purchaser must pay for shipping to Wilson Audio, and Wilson Audio will pay for shipping of its choice to return the product to purchaser. **A RETURNED PRODUCT MUST BE ACCOMPANIED BY A WRITTEN DESCRIPTION OF THE DEFECT.** Wilson Audio reserves the right to modify the design of any product without obligation to purchasers of previously manufactured products and to change the prices or specifications of any product without notice or obligation to any person.

Remedy

In the event that the product fails to meet the above Limited Warranty and the conditions set forth herein have been met, the purchaser's sole remedy under this Limited Warranty shall be to: (1) contact an authorized Wilson Audio Dealer within the Warranty Period for service or repair of the product without charge for parts or labor, which service or repair, at the Dealer's option, shall take place either at the location where the product is installed or at the Dealer's place of business; or (2) if purchaser has timely sought service or repair and the product cannot be serviced or repaired by the Dealer, then purchaser may obtain a return authorization from Wilson Audio and at purchaser's expense return the product to Wilson Audio where the defect will be rectified without charge for parts or labor.

Warranty Limited to Original Purchaser

This Limited Warranty is for the sole benefit of the original purchaser of the covered product and shall not be transferred to a subsequent purchaser of the product, unless the product is purchased by the subsequent purchaser from an authorized Wilson Audio Dealer who has certified the product in accordance with Wilson Audio standards and requirements and the certification has been accepted by Wilson Audio, in which event the Limited Warranty for the product so purchased and certified shall expire at

the end of the original Warranty Period applicable to the product.

Demonstration Equipment

Equipment, while used by an authorized dealer for demonstration purposes, is warranted to be free of manufacturing defects in materials and workmanship for a period of five (5) years from the date of shipment to the dealer. Demo equipment needing warranty service may be repaired on-site or, if necessary, correctly packed and returned to Wilson Audio by the dealer at dealer's sole expense. Wilson Audio will pay return freight of its choice. A returned product must be accompanied by a written description of the defect. Dealer owned demonstration equipment sold at retail within two (2) years of date of shipment to the dealer is warranted to the first retail customer to be free of manufacturing defects in materials and workmanship for the same time periods as if the product had originally been bought for immediate resale to the retail customer. Wilson Audio products are warranted for a period of 90 days, unless extended to 5 years, as provided above, by return and filing of completed Warranty Registration at Wilson Audio within 30 days after product delivery to customer and the product was professionally installed by the Wilson Audio Dealer that sold the product to the customer.

Miscellaneous

ALL EXPRESS AND IMPLIED WARRANTIES NOT PROVIDED FOR HEREIN ARE HEREBY EXPRESSLY DISCLAIMED. ANY LEGALLY IMPOSED IMPLIED WARRANTIES RELATING TO THE PRODUCT SHALL BE LIMITED TO THE DURATION OF THIS LIMITED WARRANTY. THIS LIMITED WARRANTY DOES NOT EXTEND TO ANY INCIDENTAL OR CONSEQUENTIAL COSTS OR DAMAGES TO THE PURCHASER.

Some states do not allow limitations on how long an implied warranty lasts or an exclusion or limitation of incidental or consequential damages, so the above limitations or exclusions may not apply to you. This Limited Warranty gives you specific legal rights, and you may also have other rights, which vary from state to state.

